

880 Performance Series™

PANEL MOUNT
INDICATOR/CONTROLLER



RICE LAKE®
WEIGHING SYSTEMS

To be the best by every measure®



Jamieson Equipment Company
www.jamiesonequipment.com
toll free 800.875.0280

880 Performance Series

PANEL MOUNT INDICATOR/CONTROLLER



Great Things come in small packages.

RICE LAKE'S 880 PERFORMANCE™ SERIES
PANEL-MOUNT INDICATOR

Extensive Endurance and Adaptability

The sleek design of the 880 not only looks great, it also fits great into existing and new panels alike. At just over four inches deep, the efficiently designed enclosure fits easily into compact spaces with built-in DIN-rail clips and pre-drilled holes to make mounting quick and effortless. The 880's modular design enables the display to be mounted up to 250 feet from the controller, useful for instances when it is inconvenient to mount the controller on a conventional panel. And communicating to a PLC independently of a display lends the 880 even greater versatility. The IP69K-rated gasket effectively resists high-pressure washdown and dust, keeping internal components out of harm's way in certain NEMA-required environments. Finally, the enhanced circuit protection is rated for industrial immunity and susceptibility from ESD/RFI/EMI, effectively filtering interference to provide stable weight values.



Modular Controller Box

Extraordinary Simplicity

The innovative 880 features multiple calibration and configuration methods. Without relying on a PLC, the 880 can batch by itself as a stand-alone controller. Intuitive multifunction menu keys provide usable navigation in any application. Quickly capture and transmit weight for optimal process monitoring and control. The multipoint and calibration functions are particularly well-suited for tank and hopper applications. Find security in the password protection for both configuration and calibration.

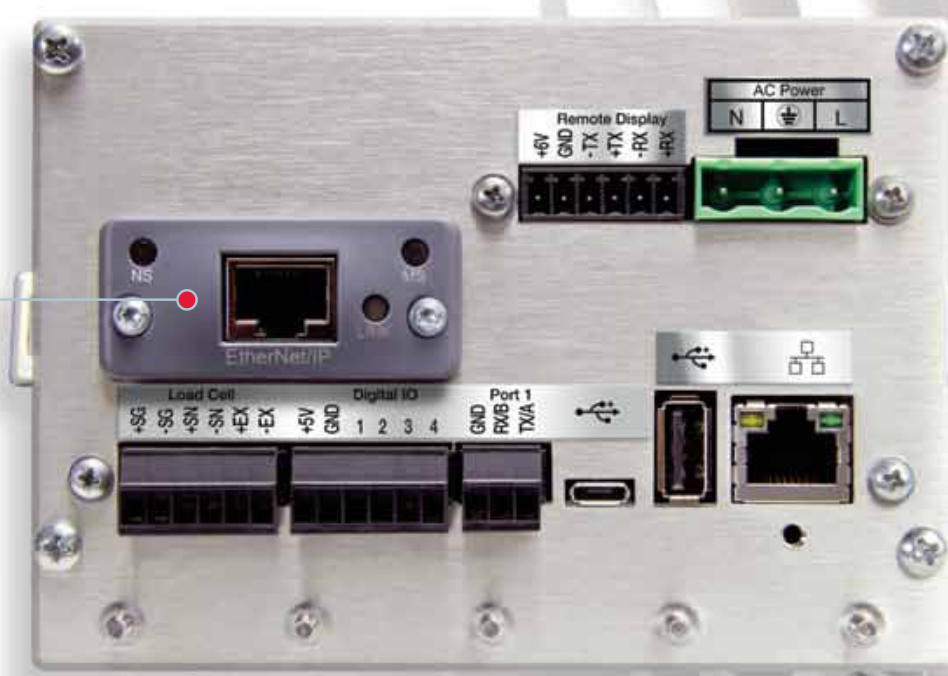

- OPTION SLOTS**
- EtherNet/IP™
 - ProfiNet®
 - ModBus TCP®
 - DeviceNet®
 - Profibus® DP
 - Analog Output
 - 4-Channel Relay

Expansive Communication

The expanded communication capabilities of the 880 Performance Series allow users to update firmware, and configure and calibrate through a USB or serial port connected to a PC. In addition, standard RS-232/RS-485 and Ethernet TCP/IP ports help make optimizing communication extremely flexible. Five available option cards can be added for communicating through interface protocols.



Exceptional Control and Configuration

Designed with the user process in mind, Rice Lake places flexibility high on the list for configuration needs, providing system functionality for optimal process control. Putting power and performance in your hand, latched and unlatched setpoints expand the process control options. The batch engine, preact, and autojog functions can be combined for ultimate control over material flow. Over 20 time- and weight-based setpoints enable this ultra-responsive controller to handle any process control requirements. As setpoints are reached, actions (activate, print, tare, accumulate and branch) can be configured based on application and need.

Excellent Adaptive Filtering

Adaptive filtering efficiently stops interference from vibration or noise, making all communications fast and credible. You can be confident that the displayed output is not only accurate, but also responsive despite environmental interference. Long-term stability is effectively improved through adaptive filtering algorithms, ignoring changes caused by vibration—saving time without sacrificing accuracy.



880 Performance Series™

PANEL MOUNT INDICATOR/CONTROLLER

Standard Features

- LED Display, 0.56inch (14mm), 14 segment
- RS-232 or RS-485 Serial Port
- USB Device
- Ethernet TCP/IP
- AC or DC models
- Built-in DIN-rail clips on controller box
- Display and controller can be separated up to 250ft
- Hardware slot for one option card
- Operator functions through Menu key for Audit Trail, Preset Tare, Accumulator, Time & Date and Setpoints
- Audit trail tracking for configuration and calibration changes. Password protection for user and configuration changes.
- 20 Setpoints with latched batch engine or unlatched outputs
- Four onboard digital I/O channels
- Programmable ticket formats up to 1000 characters for Header Text, Gross, Net, Accumulator, Setpoints
- Local/Remote operation
- Multi range or multi interval weighing
- Filter settings for light, medium and heavy noise

Options/Accessories

- Analog output, 16-bit resolution, 0-10VDC, 0-20mA, 4-20mA
- Relay output, (4) dry contact, normally open (SPST) 30VDC/250 VAC at 3 Amps
- Interface for ProfiNet®, Profibus®, Modbus TCP®, EtherNet/IP™, and DeviceNet® protocols
- Metrological hardware sealing kit
- Adapter plate for converting 310A and 520 panel mounts

Specifications

Power:	Input voltages: 100-240VAC or 9-36VDC Input Frequency: 47-63Hz
Excitation Voltage:	10VDC, 8 x 350Ω (16 x 700Ω) load cells
Input Range:	-45mV to 45mV
Sensitivity:	0.3μV/graduation minimum at 7.5Hz 1.0μV/graduation typical at 120Hz 4.0μV/graduation typical at 960Hz
A/D Sample Rate:	7.5 to 960Hz, software selectable
Resolution:	Internal: 8 million counts/23 bit Weight display: 100,000
System Linearity:	± 0.01% Full Scale
Digital I/O:	Four I/O Onboard Primary keys, Pseudo functions, Batching functions
Circuit Protection:	18KV, 10V/meter
Communication:	RS-232 Full Duplex or RS-485 Half Duplex USB Type A Connector 2.0 (Firmware update required) USB Micro A/B Connector 2.0 Ethernet TCP/IP
Display:	LED, Six 0.56inch (14mm), 14 Segment with Decimal or Comma
Annunciators:	Gross, Net, Center of Zero, Standstill, lb, kg, Tare, Preset Tare, Range 1/2/3
Keyboard:	Flat membrane panel, tactile feel
Operating Temperature:	Legal: 14°F to 104°F (-10°C to 40°C) Industrial: 14°F to 122°F (-10°C to 50°C)
Dimensions (W x H x D):	6.00 x 4.00 x 4.95in (152 x 102 x 126mm)
Weight:	2.5lb (1.2kg)
Rating:	Display Bezel NEMA 4X, IP69K
Material:	Display: Stainless Steel, Controller: Aluminum
Warranty:	Two-year limited warranty

Approvals

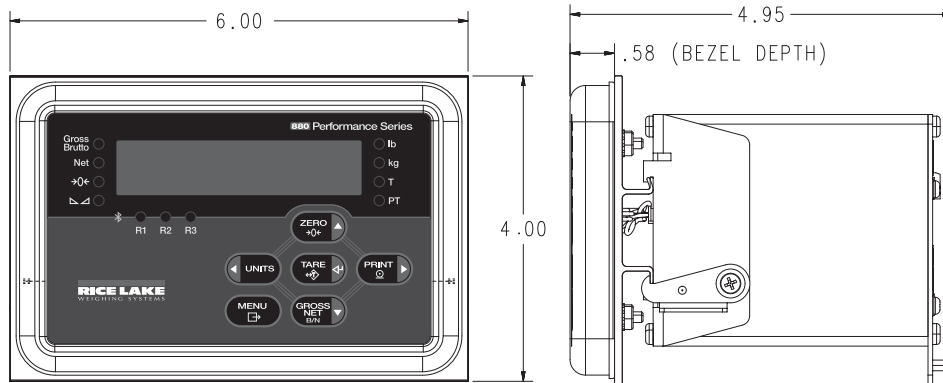

RICE LAKE
WEIGHING SYSTEMS

To be the best by every measure®